

Features

- Dual or bridge connection modes
- Few external components
- Supply voltage 3 V to 15 V
- High channel separation
- Very low switch-on/off noise
- Max gain of 45 dB with adjustable external resistor
- Soft clipping
- Thermal protection
- $P_O = 2 \cdot 1 \text{ W}$, $V_S = 6 \text{ V}$, $R_L = 4 \Omega$
- $P_O = 2 \cdot 2.3 \text{ W}$, $V_S = 9 \text{ V}$, $R_L = 4 \Omega$
- $P_O = 2 \cdot 0.1 \text{ W}$, $V_S = 3 \text{ V}$, $R_L = 4 \Omega$

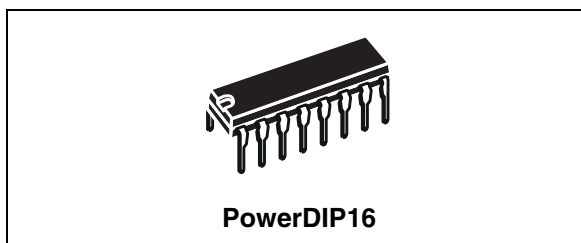

Description

The TEA2025B is a monolithic integrated circuit housed in the 12+2+2 PowerDIP16 package, intended for use as a dual or bridge power audio amplifier in portable radio cassette players.

Table 1. Device summary

Part number	Package
TEA2025B	PowerDIP16 (12+2+2)

Figure 1. Block diagram

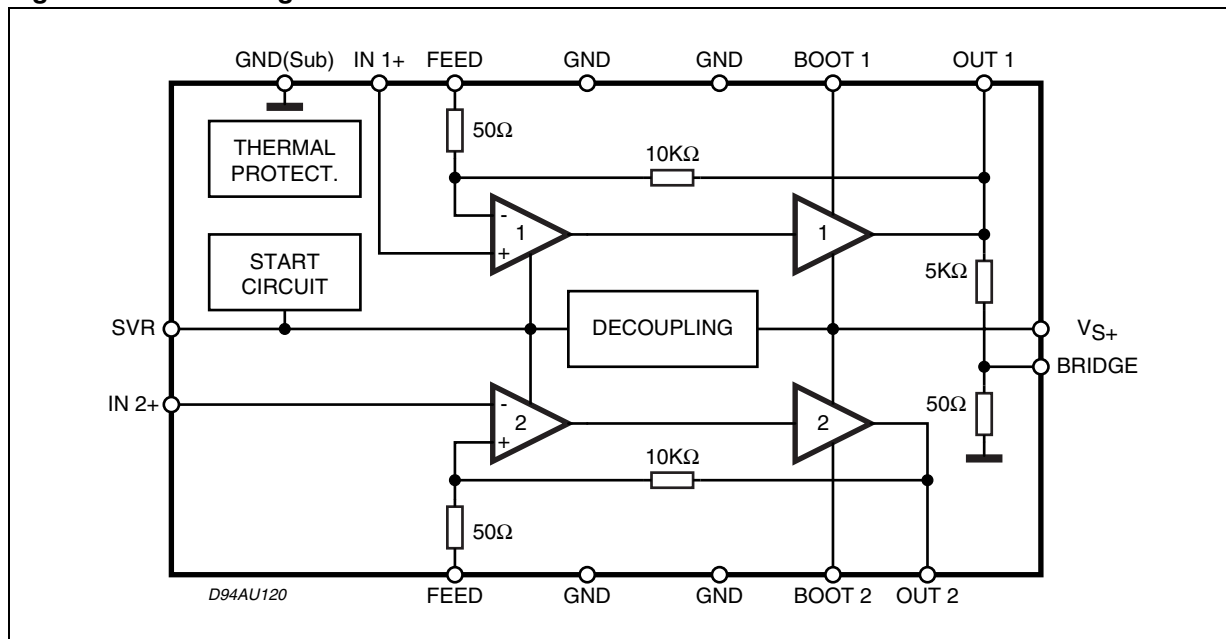

1 Device overview and electrical specifications

Table 2. Absolute maximum ratings

Symbol	Parameter	Value	Unit
V_S	Supply voltage	15	V
I_O	Output peak current	1.5	A
T_J	Junction temperature	150	°C
T_{stg}	Storage temperature	150	°C

Figure 2. Pin connections PowerDIP16 (12+2+2)

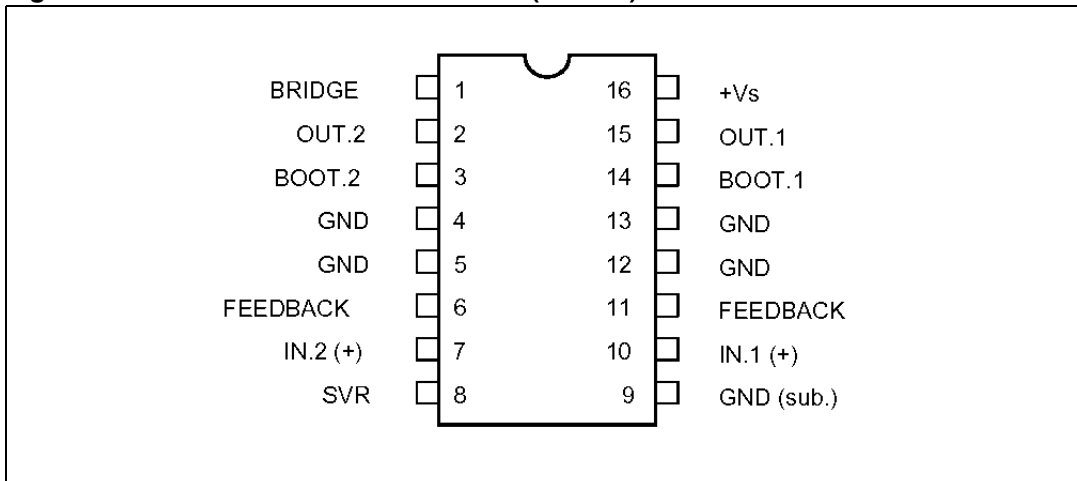

Table 3. Thermal data

Symbol	Description		PowerDIP16 (12+2+2) ⁽¹⁾	Unit
$R_{th\ j-case}$	Thermal resistance junction-case	Max	15	°C/W
$R_{th\ j-amb}$	Thermal resistance junction-ambient	Max	60	°C/W

1. $R_{th\ j-amb}$ is measured on devices bonded on a 10 x 5 x 0.15 cm glass-epoxy substrate with a 35 mm thick copper surface of 5 cm².

Table 4. Electrical characteristics ($T_{amb} = 25\text{ }^{\circ}\text{C}$, $V_S = 9\text{ V}$, stereo unless otherwise specified)

Symbol	Parameter	Test conditions	Min.	Typ.	Max.	Unit	
V_S	Supply voltage		3		12	V	
I_Q	Quiescent current			35	50	mA	
V_O	Quiescent output voltage			4.5		V	
A_V	Voltage gain	Stereo	43	45	47	dB	
		Bridge	49	51	53	dB	
ΔA_V	Voltage gain difference				± 1	dB	
R_i	Input Impedance			30		k Ω	
P_O	Output power (d = 10%)	Stereo 8 (per channel)	9 V 4 Ω	1.7	2.3		W
			9 V 8 Ω		1.3		W
			6 V 4 Ω	0.7	1		W
			6 V 8 Ω		0.6		W
			6 V 16 Ω		0.25		W
			6 V 32 Ω		0.13		W
			3 V 4 Ω		0.1		W
			3 V 32 Ω		0.02		W
		Bridge	12 V 8 Ω		2.4		W
			9 V 8 Ω		4.7		W
			6 V 4 Ω		2.8		W
			6 V 8 Ω		1.5		W
			3 V 16 Ω		0.18		W
			3 V 32 Ω		0.06		W
d	Distortion	$V_S = 9\text{ V}$; $R_L = 4\text{ }\Omega$		0.3 0.5	1.5	%	
SVR	Supply voltage rejection	$f = 100\text{ Hz}$, $V_R = 0.5\text{ V}$, $R_G = 0$	40	46		dB	
$E_{N(IN)}$	Input noise voltage	$R_G = 0$		1.5	3	mV	
		$R_G = 10\text{ k}\Omega$		3	6	mV	
CT	Crosstalk	$f = 1\text{ kHz}$, $R_g = 10\text{ k}\Omega$	40	52		dB	

Term. N° (PowerDIP16)	1	2	3	4	5	6	7	8	9	10	11	12	13	14	15	16
DC volt. (V)	0.04	4.5	8.9	0	0	0.6	0.04	8.5	0	0.04	0.6	0	0	8.9	4.5	9

Figure 3. Bridge application

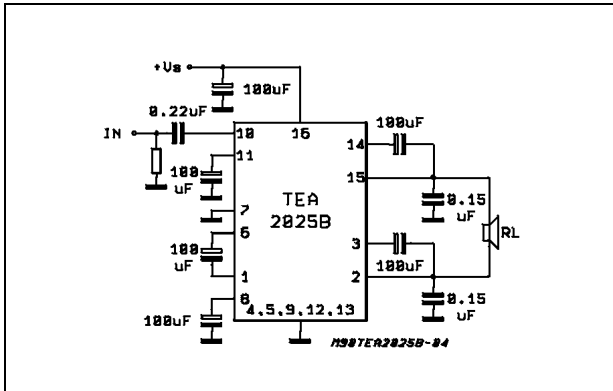

Figure 4. Stereo application

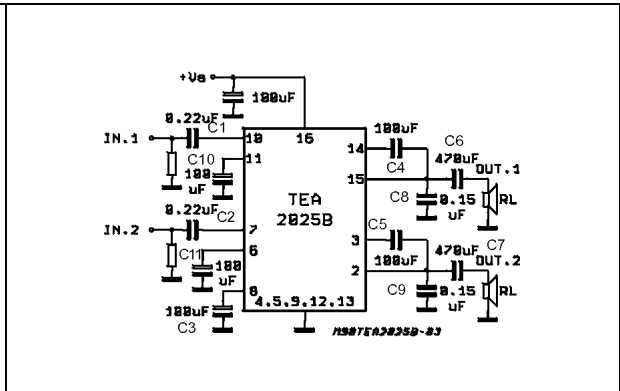

Figure 5. Supply current vs. supply voltage ($R_L = 4 \Omega$)

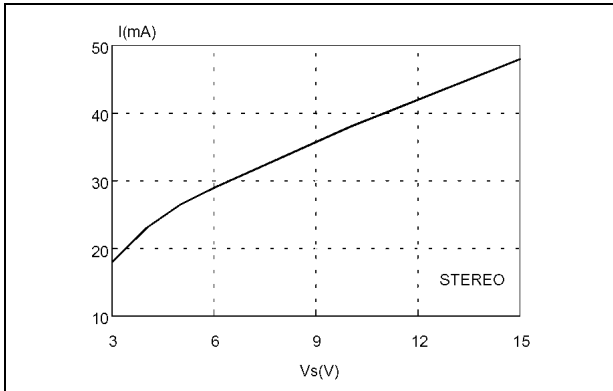

Figure 6. Output voltage vs. supply voltage

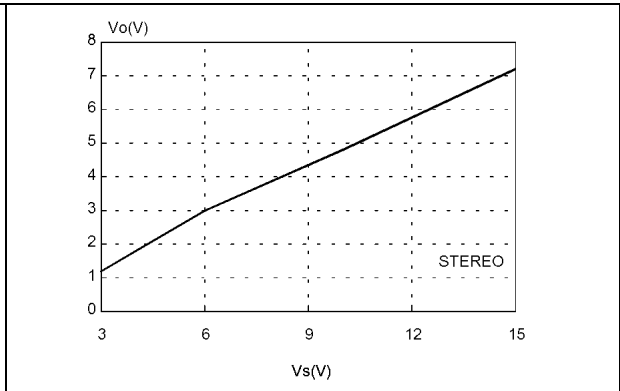

Figure 7. Output power vs. supply voltage (THD = 10%, $f = 1 \text{ kHz}$)

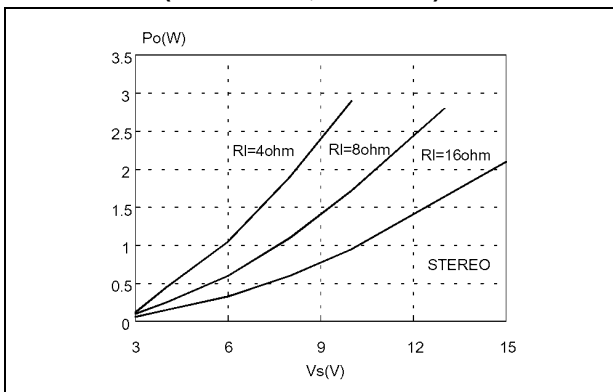
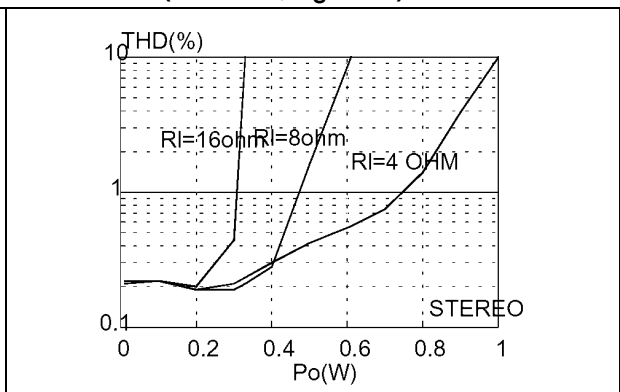

Figure 8. THD vs. output power ($f = 1 \text{ kHz}$, $V_S = 6 \text{ V}$)



2 Application information

2.1 Input capacitor

The input capacitor is PNP type allowing the source to be referenced to ground. In this way no input coupling capacitor is required. However, a series capacitor (0.22 μ F) to the input side can be useful in case of noise due to variable resistor contact.

2.2 Bootstrap

The bootstrap connection allows increasing the output swing.

The recommended value for the bootstrap capacitors (100 μ F) avoids a reduction of the output signal also at low frequencies and low supply voltages.

2.3 Voltage gain adjustment

2.3.1 Stereo mode

The voltage gain is determined by on-chip resistors R1 and R2 together with the external RfC1 series connected between pin 6 (11) and ground. The frequency response is approximated by:

$$\frac{V_{OUT}}{V_{IN}} = \frac{R1}{Rf + R2 + \frac{1}{JWC1}}$$

With Rf = 0, C1 = 100 μ F, the gain results in 46 dB with pole at f = 32 Hz.

The purpose of Rf is to reduce the gain. It is recommended to not reduce it under 36 dB.

2.3.2 Bridge mode

Figure 9. Internal voltage divider

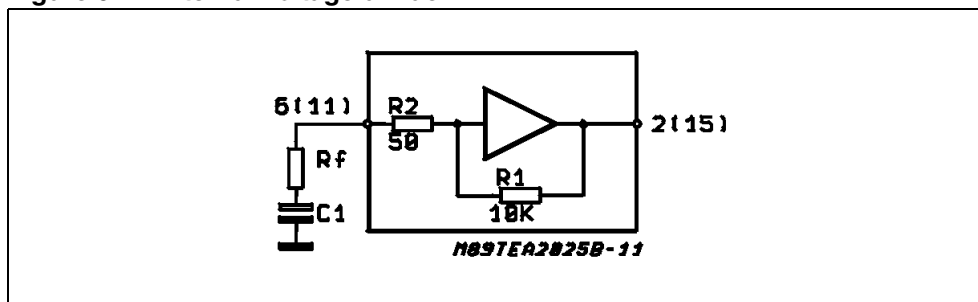

The bridge configuration is realized very easily thanks to an internal voltage divider which provides (at pin 1) the CH 1 output signal after reduction.

It is sufficient to connect pin 6 (inverting input of CH 2) with a capacitor to pin 1 and to connect pin 7 to ground. The total gain of the bridge is given by:

$$\frac{V_{OUT}}{V_{IN}} = \frac{R1}{Rf + R2 + \frac{1}{JWC1}} \left(1 + \frac{R3}{R4} \frac{R1}{R2 + R4 + \frac{1}{JWC1}} \right)$$

and with the recommended values (C1 = C2 = 100 µF, Rf= 0), then Gv = 52 dB with first pole at f = 32 Hz

Figure 10. Bridge configuration (stereo)

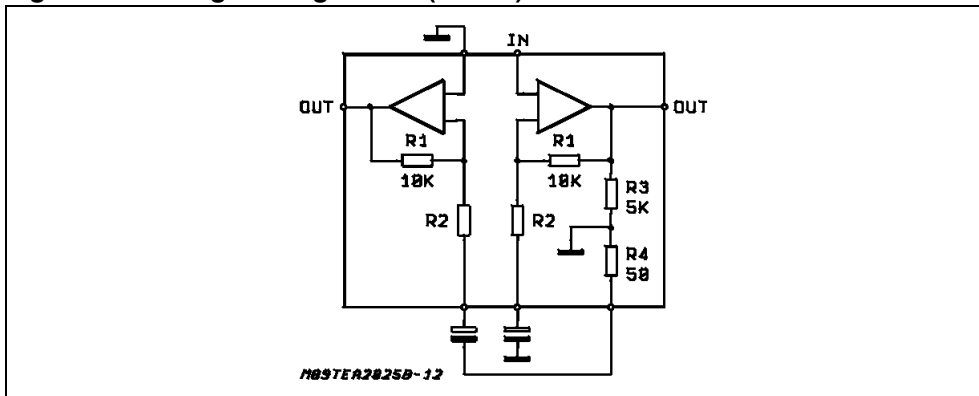

2.4 Output capacitors

The low cutoff frequency due to the output capacitor depending on the load is given by:

$$F_L = \frac{1}{2\pi C_{OUT} \cdot R_L}$$

with C_{OUT} 470 µF and R_L = 4 ohm, then F_L = 80 Hz.

2.5 Pop noise

Most amplifiers similar to the TEA2025B need external resistors between the DC outputs and ground in order to minimize pop on/off noise and crossover distortion.

Figure 11. Internal resistor

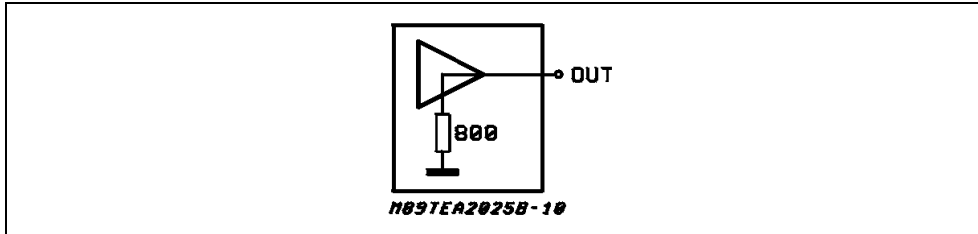

The TEA2025B requires less components as these resistors (800 ohm) are in the device.

2.6 Stability

A good layout is recommended in order to avoid oscillations.

Generally the designer must pay attention to the following points:

- Short wires of components and short connections.
 - No ground loops
 - Bypass of supply voltage with capacitors as close as possible to the supply IC pin. The low value (polyester) capacitors must have suitable temperature and frequency characteristics.
 - No sockets
- The heatsink can have a smaller factor of safety compared with that of a conventional circuit. There is no device damage in the case of excessive junction temperature: P_O (and therefore P_{tot}) and I_d are simply reduced.

3 Application suggestions

The recommended values of the components are those shown in the stereo application circuit of [Figure 4](#), although different values can be used (refer to the following table).

Table 5. Recommended values for stereo applications

Component	Recommended value	Purpose	Larger than	Smaller than
C1, C2	0.22 μ F	Input DC decoupling in case of slider contact noise of variable resistor		
C3	100 μ F	Ripple rejecton		Degradation of SVR, increase of at low frequency and low voltage
C4, C5	100 μ F	Bootstrap		
C6, C7	470 μ F	Output DC decoupling		Increase of low frequency cutoff
C8, C9	0.15 μ F	Frequency stability		Danger of oscillations
C10, C11	100 μ F	Inverting input DC decoupling		Increase of low frequency cutoff

4 Package mechanical data

In order to meet environmental requirements, ST offers these devices in different grades of ECOPACK[®] packages, depending on their level of environmental compliance. ECOPACK[®] specifications, grade definitions and product status are available at: www.st.com. ECOPACK[®] is an ST trademark.

Figure 12. PowerDIP16 mechanical data and package dimensions

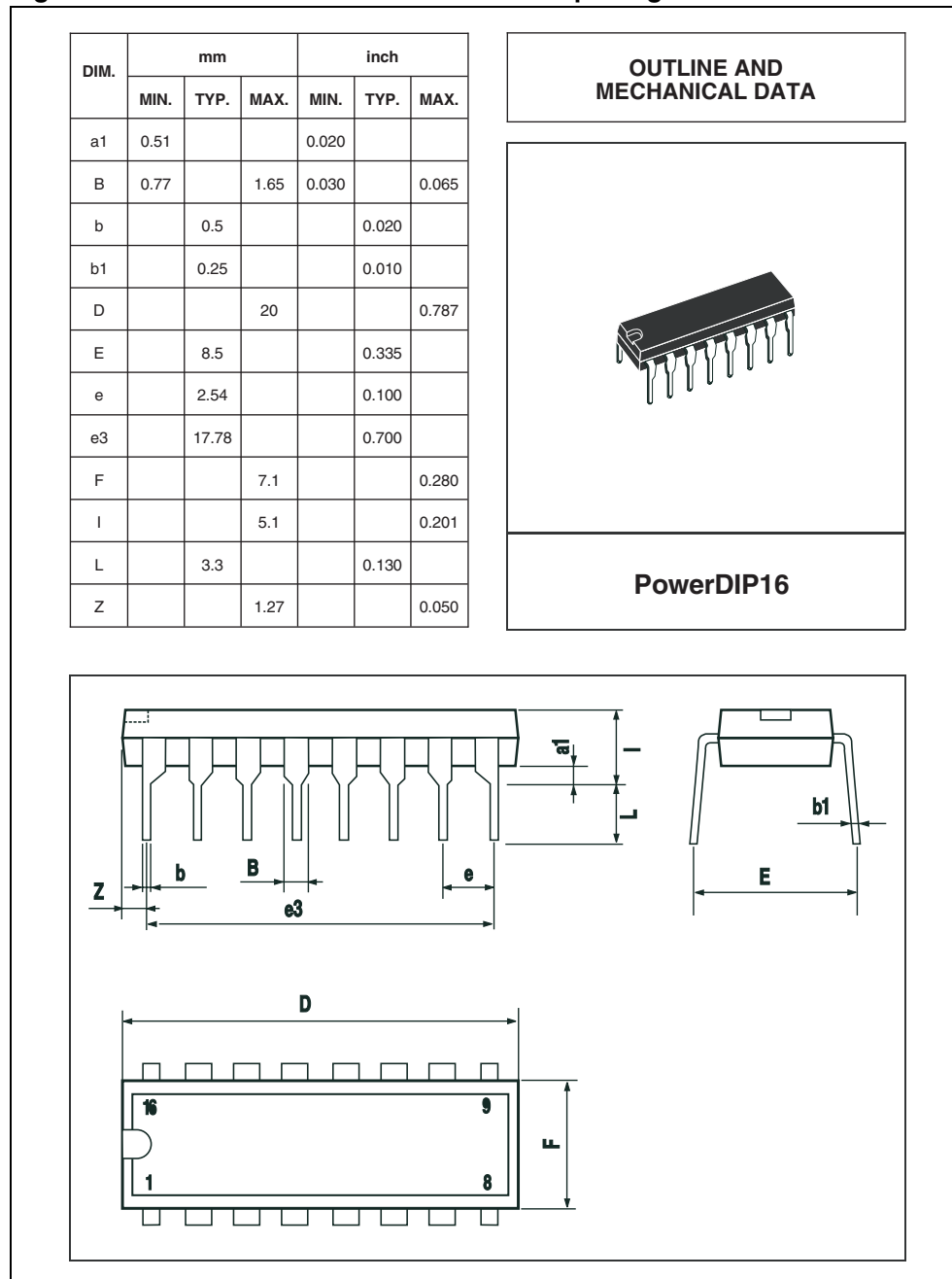

5 Revision history

Table 6. Revision history

Date	Revision	Changes
September 2003	2	Updates not recorded
30-Apr-2010	3	Updated title and added environmental compliance statement for package
01-Oct-2012	4	Removed SO20 package option from datasheet Minor textual updates Revised document presentation

Please Read Carefully:

Information in this document is provided solely in connection with ST products. STMicroelectronics NV and its subsidiaries ("ST") reserve the right to make changes, corrections, modifications or improvements, to this document, and the products and services described herein at any time, without notice.

All ST products are sold pursuant to ST's terms and conditions of sale.

Purchasers are solely responsible for the choice, selection and use of the ST products and services described herein, and ST assumes no liability whatsoever relating to the choice, selection or use of the ST products and services described herein.

No license, express or implied, by estoppel or otherwise, to any intellectual property rights is granted under this document. If any part of this document refers to any third party products or services it shall not be deemed a license grant by ST for the use of such third party products or services, or any intellectual property contained therein or considered as a warranty covering the use in any manner whatsoever of such third party products or services or any intellectual property contained therein.

UNLESS OTHERWISE SET FORTH IN ST'S TERMS AND CONDITIONS OF SALE ST DISCLAIMS ANY EXPRESS OR IMPLIED WARRANTY WITH RESPECT TO THE USE AND/OR SALE OF ST PRODUCTS INCLUDING WITHOUT LIMITATION IMPLIED WARRANTIES OF MERCHANTABILITY, FITNESS FOR A PARTICULAR PURPOSE (AND THEIR EQUIVALENTS UNDER THE LAWS OF ANY JURISDICTION), OR INFRINGEMENT OF ANY PATENT, COPYRIGHT OR OTHER INTELLECTUAL PROPERTY RIGHT.

UNLESS EXPRESSLY APPROVED IN WRITING BY TWO AUTHORIZED ST REPRESENTATIVES, ST PRODUCTS ARE NOT RECOMMENDED, AUTHORIZED OR WARRANTED FOR USE IN MILITARY, AIR CRAFT, SPACE, LIFE SAVING, OR LIFE SUSTAINING APPLICATIONS, NOR IN PRODUCTS OR SYSTEMS WHERE FAILURE OR MALFUNCTION MAY RESULT IN PERSONAL INJURY, DEATH, OR SEVERE PROPERTY OR ENVIRONMENTAL DAMAGE. ST PRODUCTS WHICH ARE NOT SPECIFIED AS "AUTOMOTIVE GRADE" MAY ONLY BE USED IN AUTOMOTIVE APPLICATIONS AT USER'S OWN RISK.

Resale of ST products with provisions different from the statements and/or technical features set forth in this document shall immediately void any warranty granted by ST for the ST product or service described herein and shall not create or extend in any manner whatsoever, any liability of ST.

ST and the ST logo are trademarks or registered trademarks of ST in various countries.

Information in this document supersedes and replaces all information previously supplied.

The ST logo is a registered trademark of STMicroelectronics. All other names are the property of their respective owners.

© 2012 STMicroelectronics - All rights reserved

STMicroelectronics group of companies

Australia - Belgium - Brazil - Canada - China - Czech Republic - Finland - France - Germany - Hong Kong - India - Israel - Italy - Japan - Malaysia - Malta - Morocco - Philippines - Singapore - Spain - Sweden - Switzerland - United Kingdom - United States of America

www.st.com

